

# G:B:D:

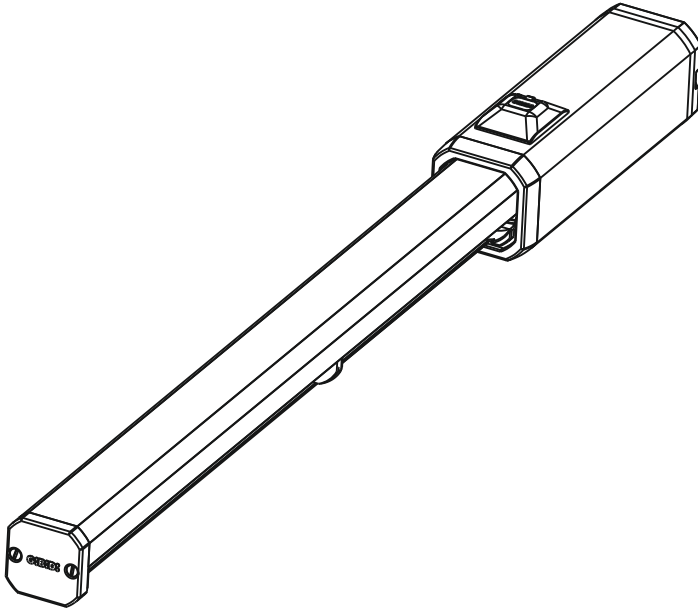

## :TOP EVO



TOP 291E(R)/(S) 115V  
TOP 391E(R)/(S) 115V  
TOP 441E(R)/(S) 115V

**Operatore oleodinamico lineare**  
ISTRUZIONI PER L'INSTALLAZIONE

**Linear hydraulic operator**  
INSTRUCTIONS FOR INSTALLATION

**Opérateur hydraulique linéaire**  
INSTRUCTIONS POUR L'INSTALLATION

**Operador hidráulico lineal**  
INSTRUCCIONES PARA LA INSTALACIÓN

IT

UK

FR

ES

DISEGNI TECNICI • TECHNICAL DRAWINGS • DESSINS TECHNIQUES • DISEÑOS TÉCNICOS

1

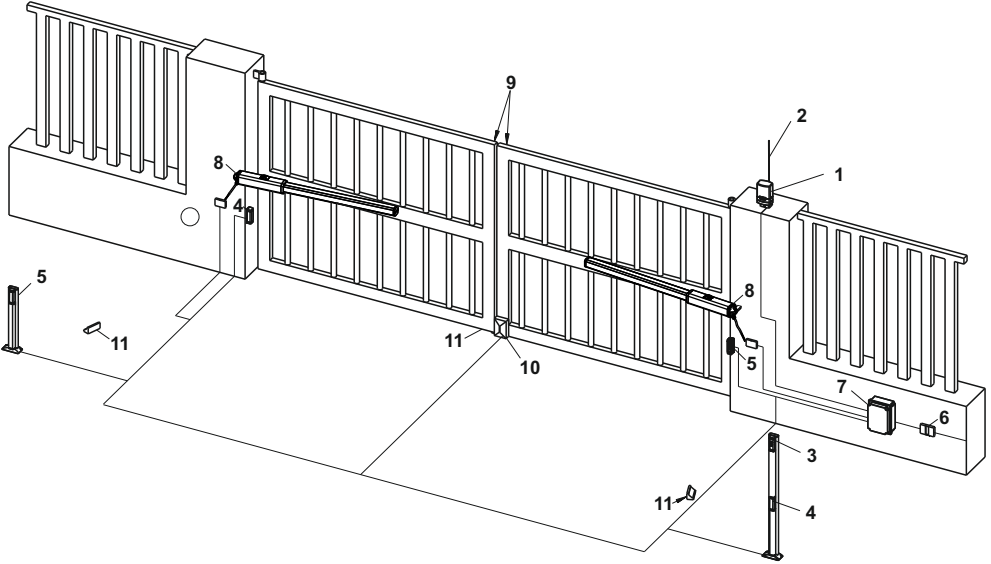

2a

TOP291E(R)/(S)

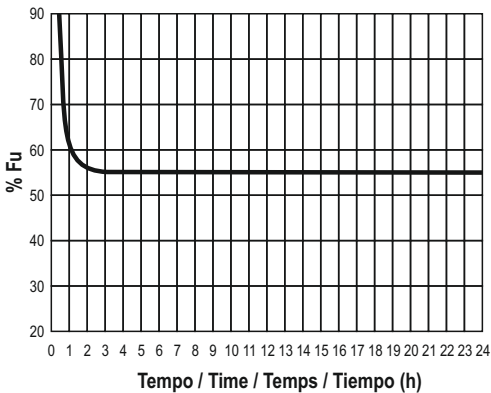

2b

TOP 391E - TOP 441E(R)/(S)

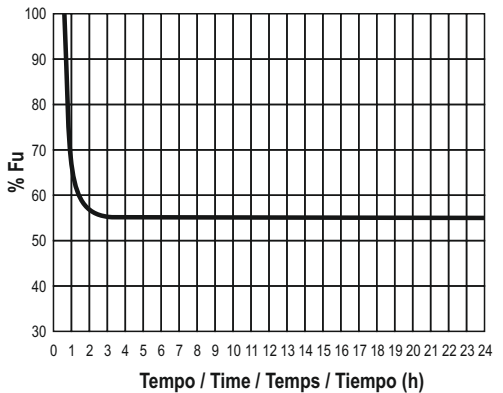

## 2c

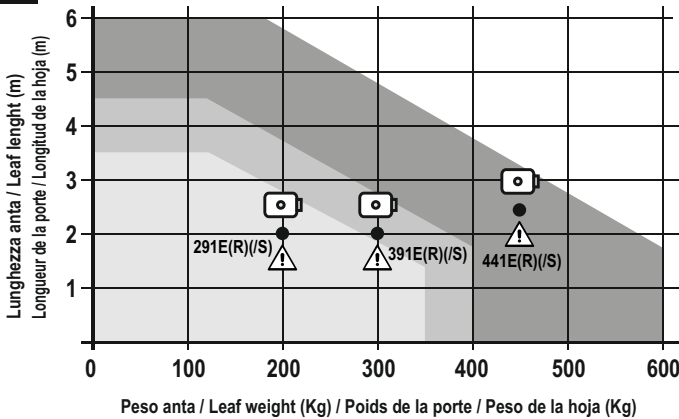

⚠ = Limite BAC  
 BAC Limit  
 Limite BAC  
 Limite BAC

□ = Elettroserratura  
 Electric lock  
 Serrure électrique  
 Electro cerradura

□ TOP291E(R)/(S)  
 □ TOP391E(R)/(S)  
 □ TOP441E(R)/(S)

## 3

TOP291E

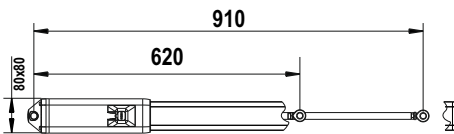

TOP291ER - TOP291ER/S

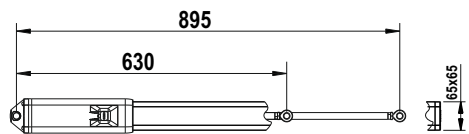

TOP391E

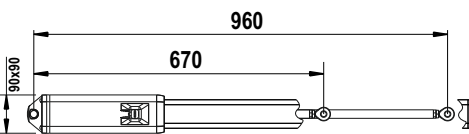

TOP391ER - TOP391ER/S

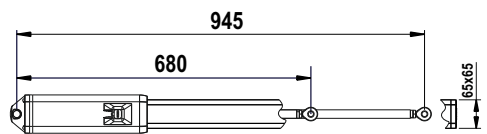

TOP441E

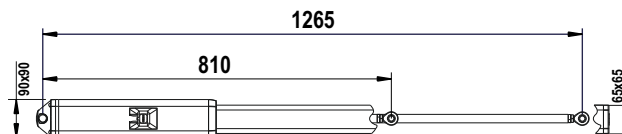

TOP441ER - TOP441ER/S

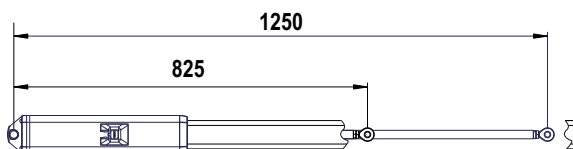

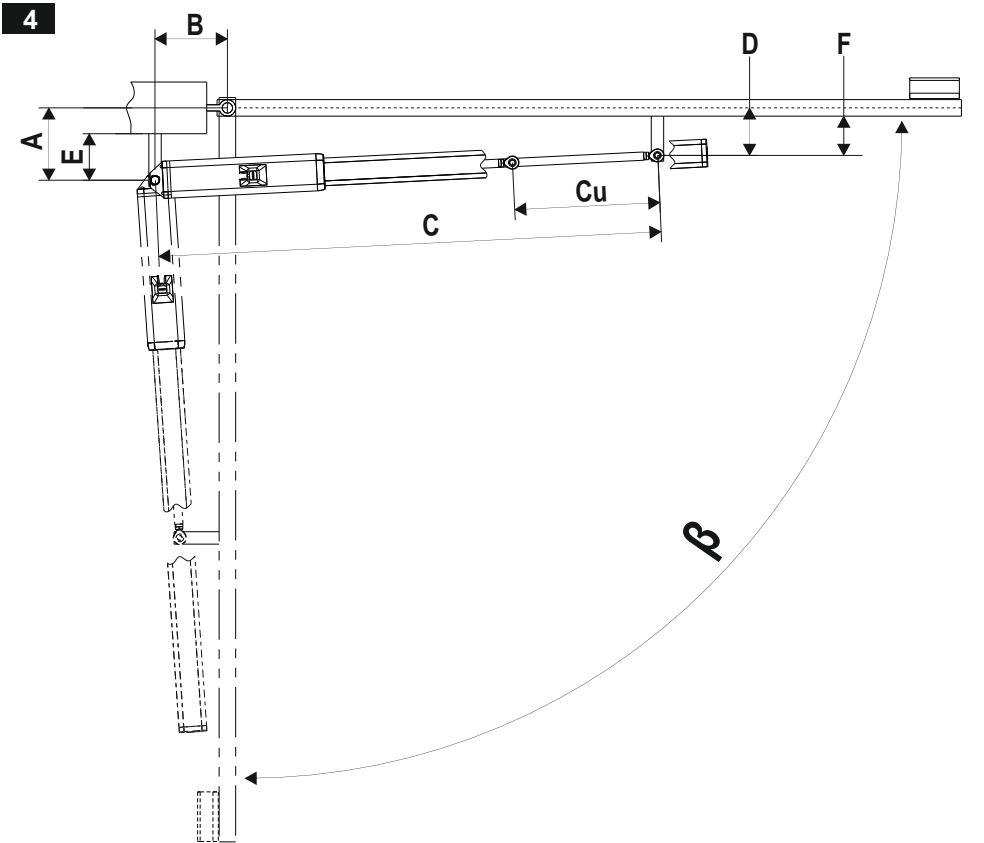

	$\beta$	A	B	C	D	Cu	E	F
TOP 291E	90°	130	130	900	100	260	>55	>80
TOP 291E	110°	110	120	900	95	265		
TOP 291ER-ER/S	90°	125	125	885	95	250		
TOP 291ER-ER/S	105°	110	110	885	95	245		
TOP 391E	90°	130	130	950	100	260		
TOP 391E	110°	110	120	950	95	260		
TOP 391ER-ER/S	90°	125	125	940	100	250	>65	>100
TOP 391ER-ER/S	105°	110	115	940	95	250		
TOP 441E	90°	205	205	1243	125	410		
TOP 441E	110°	175	175	1243	120	410		
TOP 441ER-ER/S	90°	200	200	1243	120	400		
TOP 441ER-ER/S	110°	175	175	1243	120	400		

5

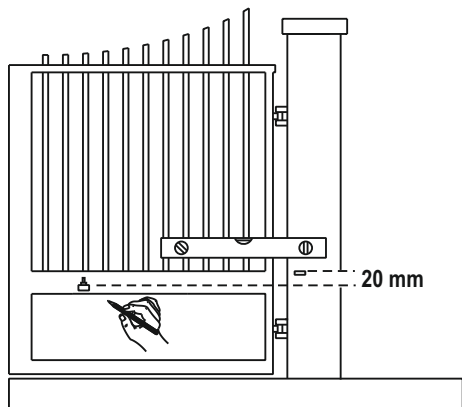

6

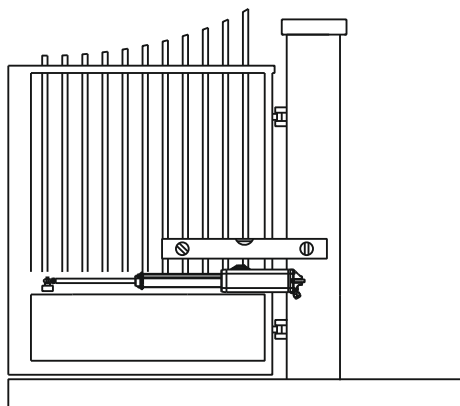

7

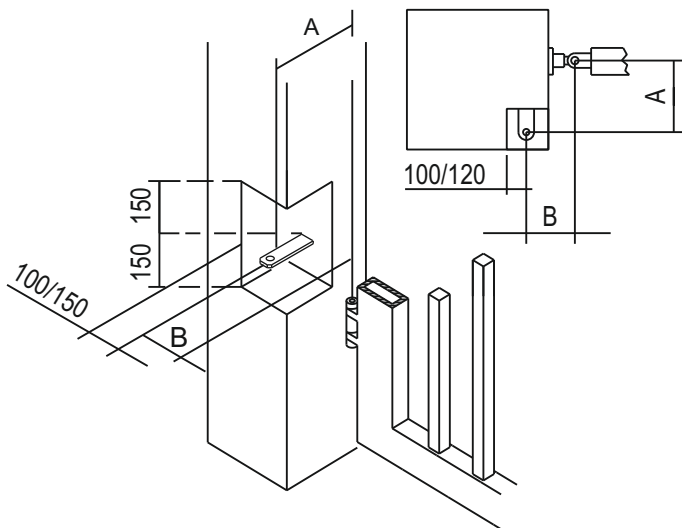

8

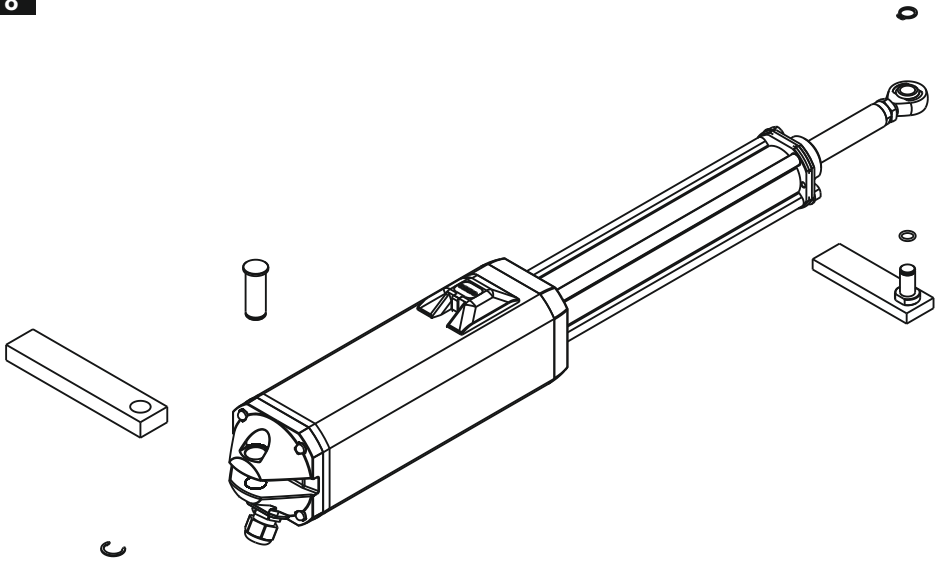

9

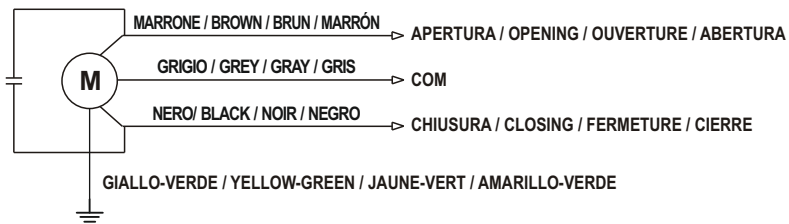
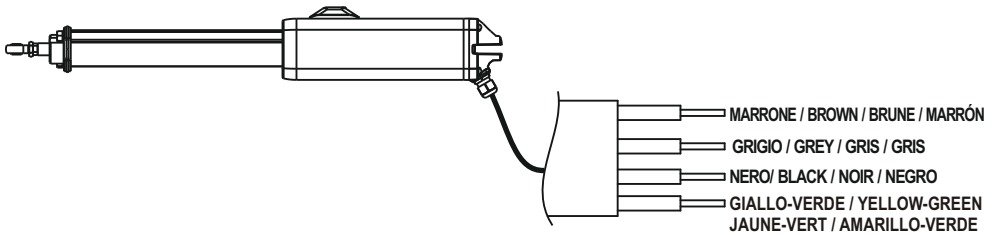

10

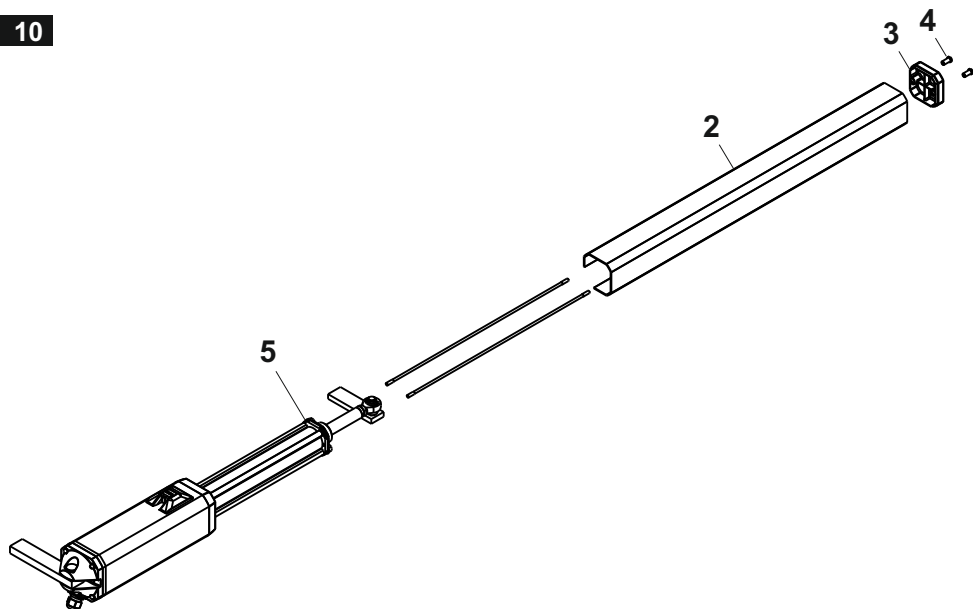

11

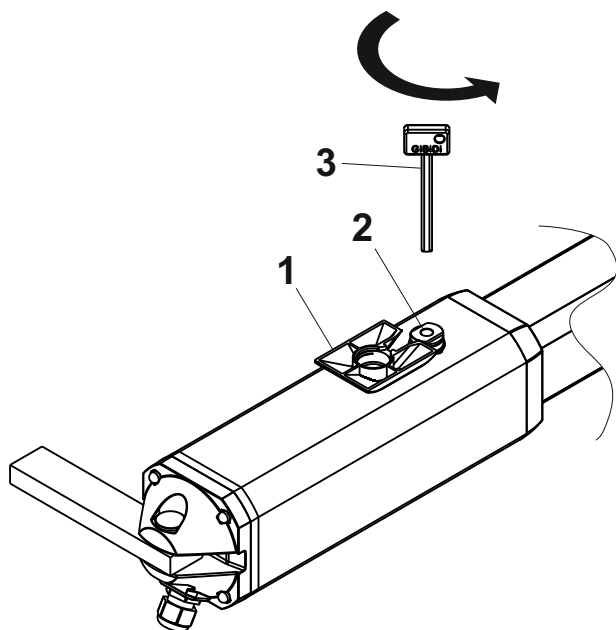

12

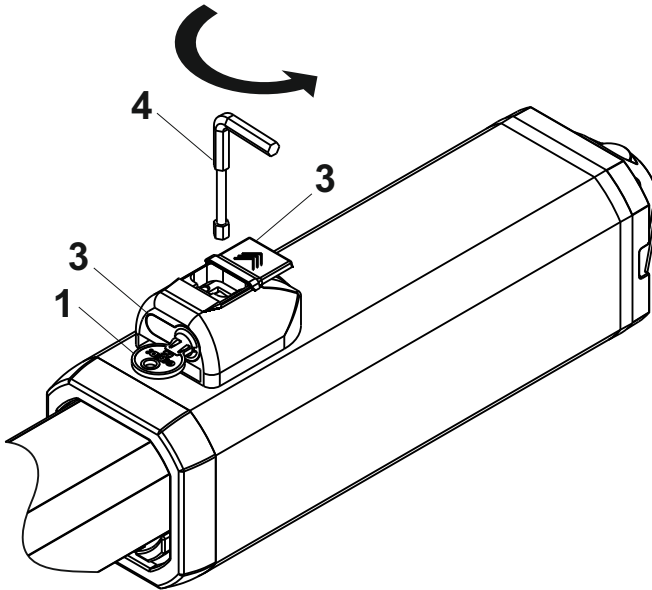

13

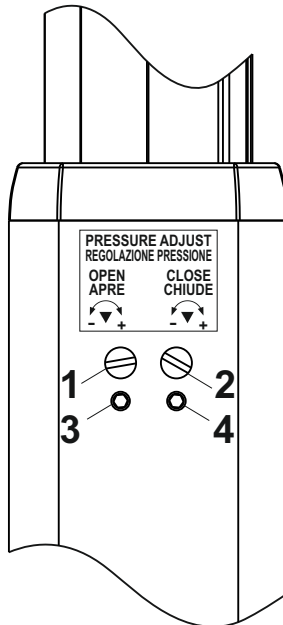

14a

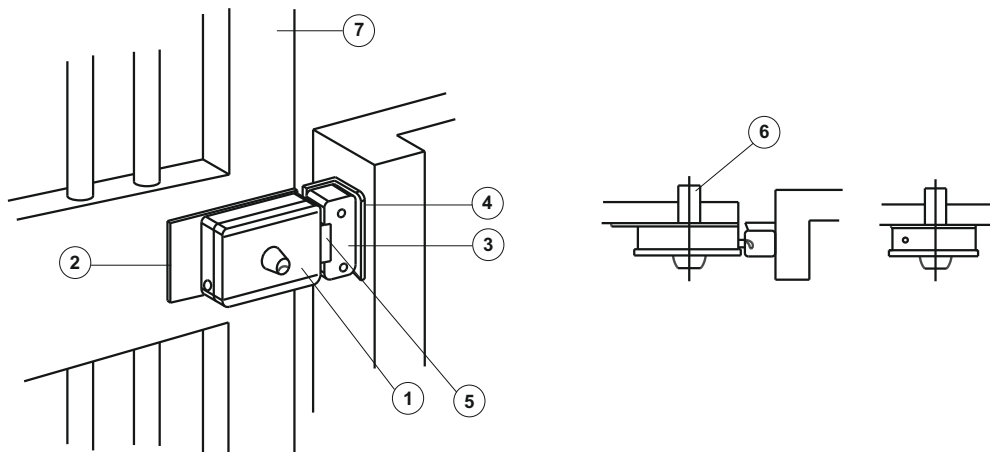

14b

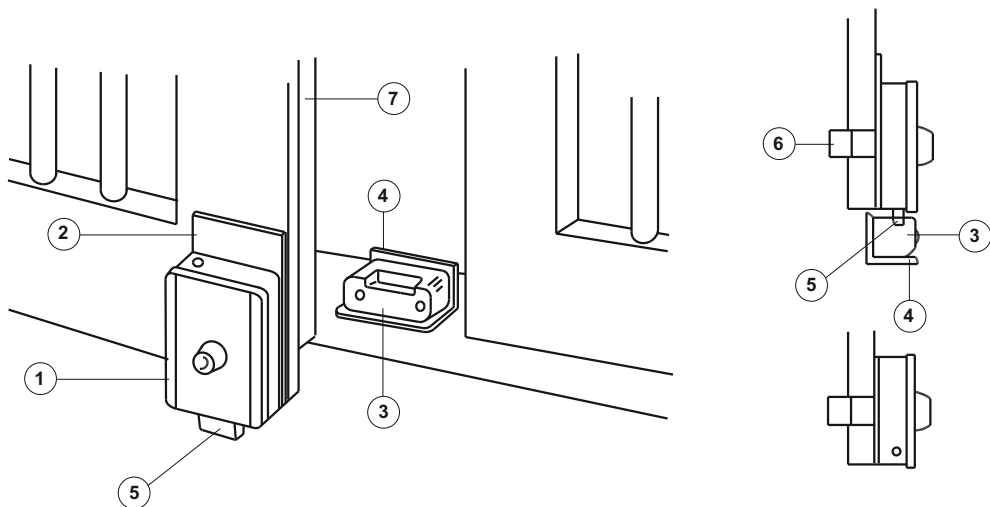

UK

Thank you for choosing G.I.B.I.D.I.

 **READ CAREFULLY THESE INSTRUCTIONS BEFORE PROCEEDING WITH INSTALLATION.**

**WARNINGS:**

This product has been tested by G.I.B.I.D.I. for full compliance with the requirements of the directives in force. G.I.B.I.D.I. S.r.l. reserves the right to change the technical data without prior notice in relation to product development.

**DISPOSAL:** G.I.B.I.D.I. advises recycling the plastic components and to dispose of them at special authorised centres for electronic components thus protecting the environment from polluting substances.



## INTRODUCTION

TOP EVO operator allows the automation of swinging gates.

The automation is composed by an operator with arm, that transmits the movement to the leaf, and by a built-in hydraulic control unit.

**TOP EVO operators are interchangeable with previous TOP versions, see chapter 8.**

## INSTALLATION WARNINGS

- Before proceeding with the installation, it is necessary to fit a magneto-thermal differential switch with a max. capacity of 10A upstream of the system. The switch must guarantee an omnipolar separation of the contacts, with an opening distance of at least 3mm.
- Keep all the materials contained in the packaging away from children since they pose a potential risk.
- The manufacturer declines all responsibility for improper functioning of the automated device, if the original components and accessories suitable for the specific application are not used.
- After installation, always carefully check the proper functioning of the system and devices used.
- This instruction manual addresses professionals qualified to install “powered equipment” and therefore requires a good technical knowledge and installation in compliance with the regulations in force.
- Maintenance must be carried out by qualified personnel.
- Before carrying out any cleaning or maintenance operation, disconnect the control unit from the main line.
- This product has been designed and constructed exclusively for the use indicated in this documentation. Any other use may cause damage to the product and be a source of danger.
- Verify the end purpose of the product and take all the necessary safety precautions.
- The use of the products for purposes different from the intended use has not been tested by the manufacturer and is therefore on full responsibility of the installer.
- Mark the automated device with visible warning plates.
- Warn the user that children or animals must not play or stand near the gate.
- Appropriately protect the dangerous points (for example, using a sensitive edge).
- Check the proper installation of the earthing system: connect all the metal parts of doors, gates, etc. and all the system components to an earth terminal.
- Exclusively use original spare parts for any maintenance or repair operation.
- Do not modify any components of the automated device unless expressly authorised by GI.BI.DI.
- Use suitable cable clamps to ensure that the wiring is properly connected mechanically and such that an IP 65 protection degree is maintained.

UK

## WARNINGS FOR THE USER

In the event of an operating fault or failure, cut the power upstream of the control unit and call Technical Service.

Periodically check the good functioning of the safety devices.

Any repair must be carried out by specialised personnel using original and certified materials.

The product must not be used by children and persons with reduced physical, sensorial or mental capacities, or without experience and knowledge.

Do not access the control unit for adjustments and/or maintenances.



### WARNING: IMPORTANT SAFETY INSTRUCTIONS

It is important to follow this instruction to safeguard persons.  
Keep this instruction manual.

## 1 - ELECTRICAL CONNECTIONS

Set up the electric system as shown in fig. [1] referring to the electric system regulations and other national regulations in force. Keep the mains power connection clearly separated from service connections (photocells, sensitive edge, control units etc.).

### The main components of the automated device are:

- ① Flashing light: 0.75 mm<sup>2</sup> 2-core (2x0,75) cable.
- ② Antenna: screened coaxial cable.
- ③ Key selector: 0,5 mm<sup>2</sup> 3-core (3x0,5) cable.
- ④ Photocell receiver: 0,5 mm<sup>2</sup> 4-core (4x0,5) cable.
- ⑤ Photocell transmitter: 0,5 mm<sup>2</sup> 2-core (2x0,5) cable.
- ⑥ Omnipolar magnetothermal differential switch with min. contact opening of 3 mm.  
110-130Vac 60Hz power line to the device: 1,5 mm<sup>2</sup> min. 3-core (3x1,5) cable (adhere to the regulations in force).
- ⑦ Case for electronic control unit: 3x1,5 mm<sup>2</sup> cable.
- ⑧ **110-130Vac operator:**  
Power supply: 1,5 mm<sup>2</sup> 4-core cable:  
**Grey = motor common; Brown = opening; Black = closing; Yellow/green = earth**
- ⑨ 8K2 sensitive edge: 0,5 mm<sup>2</sup> 2-core (2x0,5) cable.
- ⑩ Electronic lock: 1,5 mm<sup>2</sup> 2-core (2x1,5) cable.
- ⑪ Mechanical stops in opening and closing.

To lay the cables use appropriate cable ducts.

It is good practice to separate the power cables from the accessory connection cables and it is therefore advisable to use at least two tubes to run the cables through.

**WARNING:**

It is important to fit an omnipolar magnetothermal /differential switch with a min. contact opening of 3 mm on the power line upstream of the control unit.

**2 - TECHNICAL DATA**

**TOP 291E - 291ER - 291ER/S**

OPERATOR	TOP 291E	TOP 291ER	TOP 291ER/S
Operating frequency (%Fu) at 20°C	55% <b>[2a]</b>		
Electric motor	110-130 Vac		
Power absorbed	max 170 W		
Capacitor	10 µF		
Protection degree	IP65		
Maximum thrust	3000 N		2000 N
Thrust adjustment	hydraulic		
Hydraulic slowdown	no	yes	
Rod speed	12 mm/s		24 mm/s
Rod maximum stroke	290 mm	265 mm	
Hydraulic oil	GBD PH-03		
Operating temperature	from -20°C to +60°C		
Thermal protection	100°C		
Leaf maximum length	3.5 m <b>[2c]</b>		
Hydraulic lock granted for leaf maximum length	2.0 m		
Formula to calculate the operation frequency	$\%Fu = \frac{A + C}{A + C + P} \times 100$ <p>A = Opening time                      C = Closing time                      P = Overall pause time                      A+C+P = Time between two openings</p>		

UK

## 2 - TECHNICAL DATA

## TOP 391E - 391ER - 391ER/S

OPERATOR	TOP 391E	TOP 391ER	TOP 391ER/S
Operating frequency (%Fu) at 20°C	55% [2a]		
Electric motor	110-130 Vac		
Power absorbed	max 190 W		
Capacitor	10 µF		
Protection degree	IP65		
Maximum thrust	4500 N		3000 N
Thrust adjustment	hydraulic		
Hydraulic slowdown	no		yes
Rod speed	12 mm/s		24 mm/s
Rod maximum stroke	290 mm		265 mm
Hydraulic oil	GBD PH-03		
Operating temperature	from -20°C to +60°C		
Thermal protection	100°C		
Leaf maximum length	4.5 m [2c]		
Hydraulic lock granted for leaf maximum length	2.0 m		
Formula to calculate the operation frequency	$\%Fu = \frac{A + C}{A + C + P} \times 100$ <p>A = Opening time  C = Closing time  P = Overall pause time  A+C+P = Time between two openings</p>		

### 2 - TECHNICAL DATA

#### TOP 441E - 441ER - 441ER/S

OPERATOR	TOP 441E	TOP 441ER	TOP 441ER/S
Operating frequency (%Fu) at 20°C	55% <b>[2a]</b>		
Electric motor	110-130 Vac		
Power absorbed	max 190 W		
Capacitor	10 µF		
Protection degree	IP65		
Maximum thrust	4500 N	3000 N	
Thrust adjustment	hydraulic		
Hydraulic slowdown	no	yes	
Rod speed	12 mm/s	24 mm/s	
Rod maximum stroke	440 mm	425 mm	
Hydraulic oil	GBD PH-03		
Operating temperature	from -20°C to +60°C		
Thermal protection	100°C		
Leaf maximum length	6 m <b>[2c]</b>		
Hydraulic lock granted for leaf maximum length	2.0 m		
Formula to calculate the operation frequency	$\%Fu = \frac{A + C}{A + C + P} \times 100$ <p>                     A = Opening time                      C = Closing time                      P = Overall pause time                      A+C+P = Time between two openings                 </p>		

## UK

**3 - MAXIMUM OPERATING CURVE**

The operating time based on the desired operating frequency can be derived from the graphs **[2a]** and **[2b]**.

**4 - APPLICATION DIAGRAM**

The maximum leaf length related to the weight can be derived from the graph **[2c]**.

**5 - DIMENSIONS**

Refer to figure **[3]**.

**6 - PRELIMINARY WARNINGS**

- Check that the gate structure is adapted for installing the operator.
- Check that the fixed and mobile parts of the gate are structurally intact and appropriate or whether require reinforcement work.
- Check that the parts subject to friction, especially the top hinge, does not require any setup.
- In the working area of the operator there must no obstacles of any kind.
- Check the existence of an efficient earth.
- The installation should be done far away from any road, so as not to pose a threat to circulation.
- It is useful to signal the automatic entrance with easily visible warning plates (inside and outside) and, if necessary, that warn pedestrians they are not allowed to pass through.
- If the installation presents some unsafety details, stop the work and contact your dealer.
- Check that the gate structure is strong enough. In any case the operator must push the leaf at a reinforced point.
- Check that the leaves can be moved manually without effort throughout the stroke.
- Check that the mechanical stops, both in opening and closing, are correctly installed.
- If the automatic system is not a completely new installation, check the wear of all components and repare or replace the defective or worn parts.
- The reliability and safety of the automatic device are directly affected by the condition of gate structure.

## 7 - END STOPS OF THE LEAVES ON THE GROUND

For the correct operation of the actuator, use the end stops both in opening and closing.

The end stops of the leaves must prevent the actuator rod from arriving to the limit switch and must be positioned so as to keep a stroke room of the rod of about 5-10 cm, in order to avoid any possible operation anomaly.

Moreover it is recommended to use some amortised / rubber limit switch stops, in order to attenuate shock.

## 8 - MOUNTING DIMENSIONS

If it is not possible to maintain the dimensions in table [4], consider the following to calculate the measurements:

- For  $\beta = 90^\circ \rightarrow A + B = Cu$
- For  $\beta > 90^\circ \rightarrow A + B < Cu$  ( $\beta$  max  $110^\circ$ )
- Quota A must always be bigger than quota D.
- **The difference between A and B must not exceed 50 mm.** Larger differences cause an uncostant movement of the leaf (the tractive/thrust force and the movement speed vary during the manoeuvre).
- If the leaf is very thick, with consequent difficulty in respecting the dimension F, it is possible to increase the dimension D and dimensions A and B must also be increased by the same amount, maintaining anyway the rules indicated above.

## 9 - HYDRAULIC SLOWDOWNS

TOP291ER(/S), TOP391ER(/S), TOP441ER(/S) operators are equipped with hydraulic slowdowns. The hydraulic slowdown occurs during the last 45mm of rod stroke, both in opening and closing.

### WARNING:

- The intensity of the slowdown is predetermined at the factory and cannot be modified, but some little adjustments are still possible, properly acting on the thrust adjustment valves ① and ② [13].
- It is of fundamental importance to comply with the installation quotas and take into consideration what said above to make use of the hydraulic slowdowns.
- The effectiveness of the hydraulic slowdown is affected by the ambient temperature, at low temperature

## UK

## 10 - OPERATOR INSTALLATION

- 1 - Check the fixing point most suitable for the front bracket of the operator [5] and mark it.
- 2 - Indicate the point on the pillar with a spirit level to fix the rear bracket [5].
- 3 - Find the fixing point of the rear bracket in function of quotas A-B [4].  
**WARNING:** if the pillars or walls are big, you must make a niche [7], so that quotas A, B, E are met.
- 4 - Fix the rear bracket:
  - Weld (if it is an iron pillar), previously checking the column thickness. If it is less than 5mm, provide a reinforcing plate of such size that it allows making the welds on the edge of the column.
  - If it is a concrete pillar, you must make a plate 5 mm of thickness with no. 4 holes. Weld the bracket in the middle of the plate and fix it with some screws.
- 5 - Power the operator [9], bring the rod completely forward, then make it go back for **5-10 mm**.
- 6 - Fix the front bracket on the operator [8].
- 7 - ring the leaf in closing position against the mechanical stops and fix it with a clamp.
- 8 - Mount the operator on the rear bracket with the pin provided [8].
- 9 - Put the front bracket in the point previously marked at point 1, check the levelling of the operator with a spirit level and mark the exact fixing point of the front bracket [5-6].
- 10 - Remove the operator from the rear bracket.
- 11 - Remove the front bracket of the operator.
- 12 - Fix the front bracket in the point marked.  
Fixing the front bracket:
  - Weld (if it is an iron gate), previously checking the tubular thickness, where we are going to weld the bracket. If it is less than 5mm, provide a reinforcing plate of such size that it allows making the welds on the edge of the tubular.
  - If the gate is made with a material different from iron, you must make a plate 5 mm of thickness with no. 4 holes. Weld the bracket in the middle of the plate and fix it with some through screws.
- 13 - Assemble the operator on the brackets [8].
- 14 - Screw the tension rods ① [10] for 4-5 mm on the operator head.
- 15 - Lightly lubricate the seal ⑤ [10], insert the carter ② [10] and the head ③ [10].
- 16 - Fix all with the two screws provided ④ [10].

**WARNING:**

- Make the welding operations with the operator not assembled on the brackets.
- In case of heavy and/or buffered gates, it is necessary to strenghten both brackets with reinforcing hard metal plates (not provided).
- Before definitively fixing the brackets, make some manual tests of gate opening and closing, to check the installation quotas.

## 11 - MANUAL MANOEUVRE (UNLOCKING DEVICE)

### Unlocking device with hexagonal key [11]:

Turn the cover ① and lift it, turn the unlocking key ② anti-clockwise by 2 turns and carry out the manual manoeuvre.

To reset turn the key ② clockwise until it stops without forcing it, replace the cover into its original position.

### Unlocking device with personalised key [12]:

Push the cover ③ in the arrow direction, insert the key ① in the cylinder ②, turn the key clockwise, turn the unlocking key ④ anti-clockwise by 2 turns and carry out the manual manoeuvre.

To reset turn the key ④ clockwise until it stops without forcing it, turn the key ① anti-clockwise, replace the cover ③ into its original position.

**WARNING:** carry out the operations for the manual manoeuvre with the motor off.

## 12 - THRUST ADJUSTMENT

In order to increase the thrust, turn the valves ① and ② clockwise with a screwdriver [13]; in order to decrease the thrust, turn the valves anti-clockwise.

In detail :

- The valve ① [13] adjusts the OPENING thrust.
- The valve ② [13] adjusts the CLOSING thrust.

### WARNING:

When you adjust the thrust, turn the valves smoothly and gradually without unscrewing or completely screwing them, keeping in mind that the operators are provided with the thrust already adjusted in its best way during testing mode.

The operator is equipped with pressure control labels both for right and left version, already attached to the motor.

## 13 - CONVERSION FROM IRREVERSIBLE TO REVERSIBLE OPERATOR

TOP EVO operator is manufactured and sold as IRREVERSIBLE, if you need you can transform it into reversible in opening or closing or both in opening and closing.

The reversibility of the operator is controlled by the cursors ③ and ④ [13], turning them clockwise until they are blocked the operator is irreversible, turning them anti-clockwise the operator becomes reversible.

In detail with the operator installed on LEFT leaf:

- The valve ④ [13] controls the reversibility in OPENING.
- The valve ③ [13] controls the reversibility in CLOSING.

## UK

**14 - ELECTROLOCK MOUNTING**

Refers to pictures [14a] and [14b]. The electrolock must be installed on leaves longer than 2.5 m.

- ① Electrolock.
- ② Electrolock fixing plate.
- ③ Bolt hooker.
- ④ Bolt hooking rabbet.
- ⑤ Bolt.
- ⑥ Key cylinder (on request).
- ⑦ Gate.

**15 - FINAL CHECKS**

Power the automatic system:

- If installed, check the correct reading of the limit switches (optional), manually moving the leaf.

Run one or more opening and closing complete cycles checking:

- The correct operation of safety devices;
- The regular movement of the leaves;
- The solidity of the foundation plate;
- That the automatic gate complies with the essential safety requirements required by the Machinery Directive (2006/42/CE)

**16 - MAINTENANCE**

Carry out periodic checks on the gate with particular attention to:

- Check the hinges;
- Check the correct operation of safety devices;
- Unlock the operator and verify there is no friction points during the whole stroke;
- Check the self-lubricating bushing.

Periodically check the correct functioning of anti-crushing safety and the efficiency of the unlocking system which allows the manual operation (see the relevant paragraph).

The safety devices installed must be checked at least each six months.

Gi.Bi.Di. S.r.l. reserves the right to modify the technical data without prior notice, depending on product development.

**17 - MALFUNCTIONING**

In the event of any malfunction, cut the power of the system and call in a qualified technician (installer).

During out of service, activate the manual release to allow manual opening and closing.

## EU Declaration of conformity

The manufacturer: **GI.BI.DI. S.r.l.**  
Via Abetone Brennero, 177/B,  
46025 Poggio Rusco (MN) ITALY  
declares that the products:

### **HYDRAULIC OPERATORS TOP 291E(R)/(S)-391E(R)/(S)-441E(R)/(S)**

are in conformity with the following Directives:

- 2014/30/UE;
- 2014/35/UE;

and that the following harmonised standards have been applied:

- EN 61000-6-2:2005; EN 61000-6-3:2007 + A1:2011
- EN 60335-1:2002 + A1:2004 + A11:2004 + A12:2006 + A2:2006 + A13:2008 + A14:2010 + A15:2011; EN 60335-2-103:2003 + A11:2009;

The parts of the product which are subject to the following standards comply with them:

- EN 13241-1:2003 + A1:2011; EN 12445:2002; EN 12453:2002; EN 12978:2003 + A1:2009.

Moreover declares that the product must not be used until the machine in which it has been incorporated has not been declared in accordance with 2006/42/CE Directive.

Date 13/12/2021

The legal Representative  
Michele Prandi



**The UKCA declaration of conformity is available**  
at <http://conformity.gibidi.com>

# GIBIDI

**GI.BI.DI. S.r.l.**

Via Abetone Brennero, 177/B  
46025 Poggio Rusco (MN) - ITALY  
Tel. +39.0386.52.20.11  
Fax +39.0386.52.20.31  
E-mail: [info@gibidi.com](mailto:info@gibidi.com)

Numero Verde: 800.290156

[www.gibidi.com](http://www.gibidi.com)

