

G:B:D:



:DCD300

CE UK
CA

DCD300

**Waterproof multifunction keypad
with double relay for
stand-alone access control**
USER MANUAL

UK

1 - TECHNICAL SPECIFICATIONS

DCD300	
Installation	Wall mounting
Material	Metal alloy
Programming	By keypad
Power supply	12/24V ac/dc
Absorption at rest	< 50mA
Form of identification	Code / Tag RFID or both
Keypad	12 backlit metallic buttons
PIN lenght	1-8 digits (up to 100.000.000 combinations)
RFID reader	125Khz up to 6cm
Users number	1 - 999
Alarm output	Output 0V Door open too long / Door forced / Max. no. wrong attempts / Anti-tampering
Wiring connections	Relay output, Exit button, Alarm, Door Contact, Doorbell
Status and programming LED	Green, red, blue, yellow
Status and programming acoustic signal	Buzzer/Beep sound
Cable lenght	2 m
Waterproof rating	IP 66
Operating temperature / RH	from -30°C to +60°C / 98% RH
Dimensions (l x h x w)	55 x 135 x 24 mm
Gross weight	0,54 Kg

2 - FORM OF IDENTIFICATION

PIN code	>	Entry of a code (from 1 to 8 digits except 0 and 00000000), then #
Card/Tag	>	Reading of a Card/Tag
Card/Tag + PIN code	>	Reading of a Card/Tag and entry of a PIN code associated, then #
Button	>	Pressure on the keypad button

3 - INSTALLATION

Install the fixing support on a perfectly flat surface



Fix the device on the fixing support from above, then pull down

Tighten the device on the fixing support with the locking screw

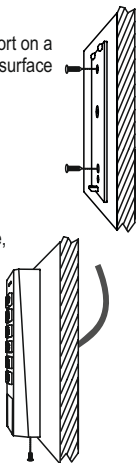

4 - WIRING DESCRIPTION

Wires	Name	Description
Red	+	Power supply 12-24V ac/dc
Black	-	Power supply 12-24V ac/dc
Blue	NO 1	Normally open Relay 1
Green	NC 1	Normally close Relay 1
White	COM 1	Common Relay 1
Blue/Black	NO 2	Normally open Relay 2
Green/Black	NC 2	Normally close Relay 2
White/Black	COM 2	Common Relay 2
Grey	GND	GND
Yellow	OPEN 1	Push button Relay 1 (PTE)
Orange	OPEN 2	Push button Relay 2 (PTE)
Brown	D_IN	Location contact of the door
Purple (*)	Alarm	Output alarm 0V if on alert

(*) usable only in DC

5 - CONNECTION DIAGRAM

5.1 - Electric lock device - de-energised to release

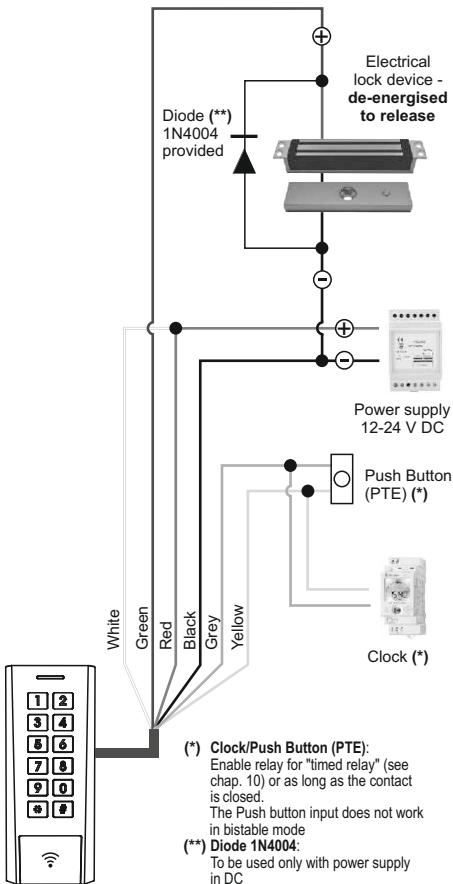

5 - CONNECTION DIAGRAM

5.2 - Electric lock - energised to release

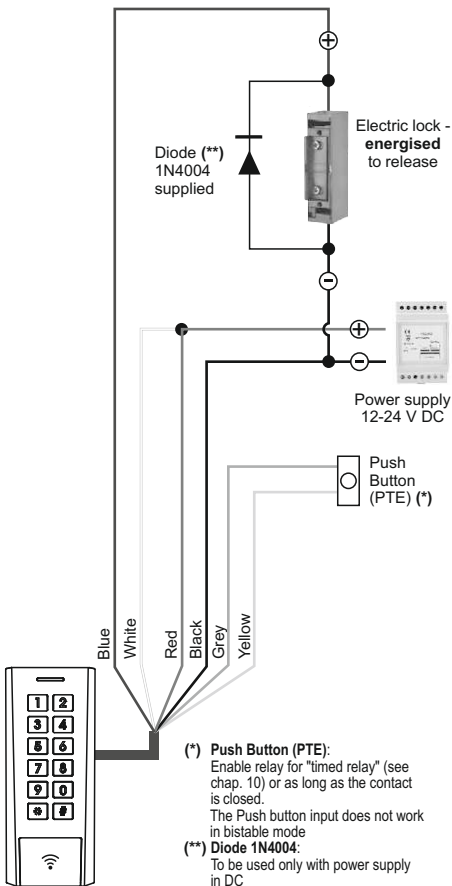

5 - CONNECTION DIAGRAM

5.3 - Device controlled by a dry contact NO



Control from dry contact NO

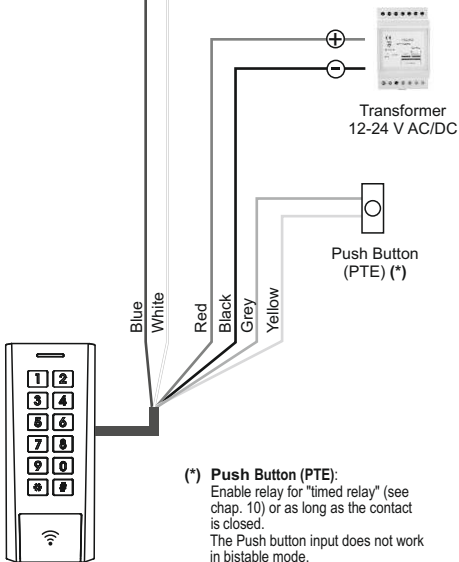

5 - CONNECTION DIAGRAM

5.4 - Connection of a door switch to manage the alarm if door open too long and/or door forced (see chap. 10)

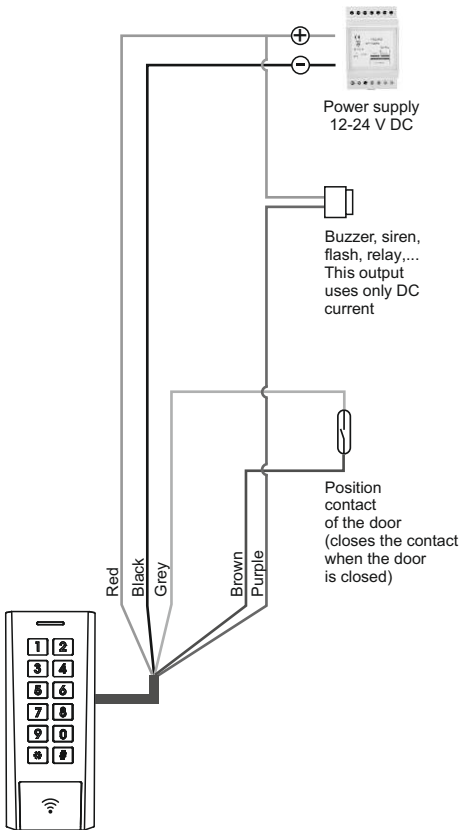

6 - FIRST POWER UP

- At first power up, the blue LED and the Buzzer works for 3s, then the device switches into "Stand-by" with flashing blue LED.
- The entry of the default PIN **8 8 8 8 8 8**, then **#** enables the relay 1 for 5s (green LED fixed).

WARNING: from the registration of the first user, the default PIN will no longer be active.

7 - ENTRY IN PROGRAMMING MODE

	Buttons	LED / Audible beep
1	* (you have 20s to type enter the Master code)	yellow LED
2	Type the Master code 8 8 8 8 8 8 then #	yellow LED
3	<p>The device is in programming mode, proceed with the required function:</p> <p>Users Programming and Cancellation:</p> <ul style="list-style-type: none"> • Programming of a PIN code or a Card/Tag Chap. 9.1 • Programming of Card/Tag in succession Chap. 9.2 • Programming of Card/Tag + PIN Chap. 9.3 • User/s Cancellation Chap. 9.4 <p>Advanced functions:</p> <ul style="list-style-type: none"> • Relay 1 configuration Chap. 10.1 • Relay 2 configuration Chap. 10.2 • Doorbell button configuration Chap. 10.3 • Keypad backlight Chap. 10.4 • Buzzer sound volume Chap. 10.5 • "Door open too long" alarm Chap. 11.1 • "Door forced" alarm Chap. 11.2 • Max. no. of wrong attempts alarm Chap. 11.3 • Anti-tampering alarm Chap. 11.4 • Back to factory parameters Chap. 12 	
4	* to exit from Programming mode (a)	Blue LED
(a) Without any action, the device automatically exits from Programming mode after 60 sec.		

8 - CHANGE OF DEFAULT MASTER CODE



WARNING: Change the default Master Code at your first installation.

Default Master code =

8	8	8	8	8	8
---	---	---	---	---	---

New Master code =

The device must be in Programming mode, see Chap. 7

	Buttons	LED / Audible beep	
1	<table border="1" style="display: inline-table; vertical-align: middle;"><tr><td>0</td></tr></table> (enables the function)	0	Yellow LED
0			
2	Enter the new Master Code (from 4 to 8 digits, except 0 and 00000000) then press <table border="1" style="display: inline-table; vertical-align: middle;"><tr><td>#</td></tr></table>	#	Yellow LED
#			
3	Enter the new Master Code again, then press <table border="1" style="display: inline-table; vertical-align: middle;"><tr><td>#</td></tr></table>	#	OK = Green LED + 2 Beeps Error = Red LED + 5 Beeps
#			
4	Enter another function or press <table border="1" style="display: inline-table; vertical-align: middle;"><tr><td>*</td></tr></table> to exit from Programming mode	*	Yellow LED OR Blue LED
*			

9 - USERS ADDITION AND CANCELLATION

9.1 - ADDITION OF A PIN OR A CARD/TAG

The device must be in Programming mode, see Chap. 7

	Buttons	LED / Audible beep					
1	<table border="1" style="display: inline-table; vertical-align: middle;"><tr><td>1</td></tr></table> <table border="1" style="display: inline-table; vertical-align: middle;"><tr><td>1</td></tr></table> (enables the function)	1	1	Yellow LED			
1							
1							
2	Enter a User ID from 1 to 999, then press <table border="1" style="display: inline-table; vertical-align: middle;"><tr><td>#</td></tr></table>	#	Yellow LED				
#							
3	Choose the relay associated to the User ID chosen: <table border="1" style="display: inline-table; vertical-align: middle;"><tr><td>1</td></tr></table> = relay 1, or <table border="1" style="display: inline-table; vertical-align: middle;"><tr><td>2</td></tr></table> = relay 2 ^(a) , or <table border="1" style="display: inline-table; vertical-align: middle;"><tr><td>1</td></tr></table> <table border="1" style="display: inline-table; vertical-align: middle;"><tr><td>2</td></tr></table> = relay 1 and 2 ^(a) , simultaneously, then press <table border="1" style="display: inline-table; vertical-align: middle;"><tr><td>#</td></tr></table>	1	2	1	2	#	Yellow LED
1							
2							
1							
2							
#							
4A OR	Addition of a PIN Enter a PIN (from 1 to 8 digits, except 0 and 00000000), then press <table border="1" style="display: inline-table; vertical-align: middle;"><tr><td>#</td></tr></table>	#	OK = Green LED + 1 Beep Error = Red LED + 5 Beeps				
#							
4B	Addition of a Card/Tag Read the Card/Tag or enter the number ^(b) of the Card/Tag, then press <table border="1" style="display: inline-table; vertical-align: middle;"><tr><td>#</td></tr></table>	#	OK = Green LED + 1 Beep Error = Red LED + 5 Beeps				
#							

-	Resume from point 1 to add another user	
5	Enter another function or press * to exit from Programming mode	Yellow LED OR Blue LED

9.2 - ADDITION OF CARD/TAG IN SUCCESSION

The device must be in Programming mode, see Chap. 7

	Buttons	LED / Audible beep
1	1 2 (enables the function)	Yellow LED
2	Enter User ID of the 1st user between 1 and 999, then press #	Yellow LED
3	Choose the relay you must associate to User ID: 1 = relay 1, or 2 = relay 2(a), or 1 2 = relay 1 and 2(a), simultaneously, then press #	Yellow LED
4	Read the Card/Tag in succession, then press #	OK = Green LED + 1 Beep Error = Red LED + 5 Beeps
5	Enter another function or press * to exit from Programming mode	Yellow LED OR Blue LED

9.3 - ADDITION OF A CARD/TAG + PIN

The device must be in Programming mode, see Chap. 7

	Buttons	LED / Audible beep
1	1 5 (enables the function)	Yellow LED
2	Enter a User ID from 1 to 999, then press #	Yellow LED
3	Choose the relay associated to the User ID chosen: 1 = relay 1, or 2 = relay 2(a), or 1 2 = relay 1 and 2(a), simultaneously, then press #	Yellow LED
4	Press a PIN (from 1 to 8 digits, except 0 and 00000000), then press #	Yellow LED Error = Red LED + 5 Beeps

5	Read the Card/Tag or enter the number ^(b) of the Card/Tag, then press #	OK = Green LED + 1 Beep Error = Red LED + 5 Beeps
-	Resume from point 1 to add other user	
6	Enter another function or press * to exit from Programming mode	Yellow LED OR Blue LED

9.4 - USER/S CANCELLATION

The device must be in Programming mode, see Chap. 7

	Buttons	LED / Audible beep
1	2 (enables the function)	Yellow LED
2A or 2B	<p>Cancellation of a user Enter the User ID from 1 to 999, or read the corresponding Card/Tag or enter the number^(b) of the Card/Tag, then press #</p> <p>Cancellation of all the users Enter 0 0 0 0 0 0 0 0 0 then press #</p>	<p>OK = Green LED + 1 Beep Error = 3 Beeps</p> <p>OK = Green LED + 1 Beep Error = 3 Beeps</p>
3	Enter another function or press * to exit from Programming mode	Yellow LED OR Blue LED

(a) It is impossible to assign the Relay 2 to a user if it is programmed as “Doorbell button”.

(b) The Card/Tag Number must be composed by 10 digits:

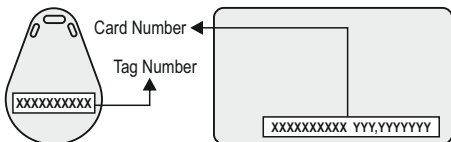

! It is impossible to program the same user on more positions

! It is impossible to replace a user without having cancelled it previously.

10 - ADVANCED FUNCTIONS

10.1 - RELAY 1 CONFIGURATION

The device must be in Configuration mode, see Chap. 7

	Buttons	LED / Audible beep
1	[3] [1] (enables the function)	Yellow LED
2A OR	Timed relay (default adjustment at 5 sec.). Enter the duration from 1 to 300 sec., then press [#]	OK = Green LED + 2 Beeps Error = Red LED + 5 Beeps
	Bistable relay (ON/OFF). Press [0], then [#]. (In this mode, OPEN 1 input cannot be used)	OK = Green LED + 2 Beeps Error = Red LED + 5 Beeps
3	Enter other function or press [*] to get out from Programming mode	Yellow LED OR Blue LED

10.2 - RELAY 2 CONFIGURATION

The device must be in Configuration mode, see Chap. 7

	Buttons	LED / Audible beep
1	[3] [2] (enables the function)	Yellow LED
2A OR	Timed relay (default adjustment at 5 sec.). Enter the duration from 1 to 300 sec., then press [#]	OK = Green LED + 2 Beeps Error = Red LED + 5 Beeps
	Bistable relay (ON/OFF). Press [0], then [#]. (In this mode, OPEN 2 input cannot be used)	OK = Green LED + 2 Beeps Error = Red LED + 5 Beeps
3	Enter another function or press [*] to exit from Programming mode	Yellow LED OR Blue LED

10.3 - DOORBELL BUTTON CONFIGURATION

If configured to do so (see below), by pressing buttons [0] then [#], Relay 2 will act as a door bell output for a duration programmable between 1 and 300 s. If Relay 2 is assigned to a User ID, it is not possible to enable the Doorbell button mode.

The device must be in ProgramminG mode, see Chap. 7

	Buttons	LED / Audible beep
1	[4] (enables the function)	Yellow LED
2A1	Enabling of Doorbell button mode. Press [1], then [#]	OK = Green LED + 1 Beep
2A2	Enter the duration from 1 to 300 s, then press [#]	OK = Green LED + 2 Beeps Error = 3 Beeps
OR		
2B	Disabling Doorbell button mode (default adjustment). Press [2] then [#]	OK = Green LED + 2 Beeps Error = 3 Beeps
3	Enter another function or press [*] to exit from Programming mode	Yellow LED OR Blue LED

10.4 - KEYPAD BACKLIGHT

The device must be in Programming mode, see Chap. 7

	Buttons	LED / Audible beep
1	[5] [1] (enables the function)	Yellow LED
2A	Backlight always on (default adjustment). Press [1] then [#]	OK = Green LED + 2 Beeps Error = Red LED + 5 Beeps
OR		
2B	Backlight always off Press [2] then [#]	OK = Green LED + 2 Beeps Error = Red LED + 5 Beeps
OR		
2C	Backlight automatically off after 60 sec.^(a) Press [3] then [#]	OK = Green LED + 2 Beeps Error = Red LED + 5 Beeps
3	Enter another function or press [*] to exit from Programming mode	Yellow LED OR Blue LED
(a) In automatic mode, after 60 s. the keypad turns on again when you push a button, that is not considered part of a code		

10.5 - BUZZER SOUND VOLUME

Buzzer volume when you enter a code or read a Card/Tag.

The device must be in Programming mode, see Chap. 7

	Buttons	LED / Audible beep
1	[6] [1] (enables the function)	Yellow LED
2	Adjust the volume from 0 to 5 (0 = Off / 5 = Max), then press [#]. Default adjustment = volume at 3.	OK = Green LED + 2 Beeps Error = Red LED + 5 Beeps
3	Enter another function or press [*] to exit from Programming mode	Yellow LED OR Blue LED
The sound level of Programming mode and alarm is not adjustable		

11 - ALARMS CONFIGURATION



The alarm for door open too long and door forced needs the connection of a door switch (for ex. magnetic contact) between the brown wire (D_IN) and the grey wire (GND). This contact must be closed when the door is closed.

11.1 - "DOOR OPEN TOO LONG" ALARM

Interruption of the alarm by simply closing the door, a Card/Tag reading or the entering of a valid PIN code.

The device must be in Programming mode, see Chap. 7

	Buttons	LED / Audible beep
1	[7] [1] (enables the function)	Yellow LED
2A1	Enables the open door detection. Press [1] then [#]	OK = Green LED + 1 Beep
2A2	Enter the opening duration before the alarm from 1 to 300 sec., then press [#]	OK = Green LED + 1 Beep Error = 3 Beeps
2A3	Buzzer: [1] = Enabled / [2] = Disabled (during the alarm) then press [#]	OK = Green LED + 1 Beep Error = 3 Beeps

2A4 OR 2B	Alarm output (a): 1 = Enabled / 2 = Disabled (during the alarm) then press #	OK = Green LED + 2 Beepd Error = 3 Beeps
	Disables open door detection (default adjustment) Press 2 then #	OK = Green LED + 2 Beeps Error = 3 Beeps
3	Enter another function or press * to exit from Programming mode	Yellow LED OR Blue LED
(a) The alarm output works only when the device is powered in DC		

11.2 - "DOOR FORCED" ALARM

Interruption of the alarm by simply closing the door and waiting for the end of alarm duration, or by a Card/Tag reading or the entering of a valid PIN code.

The device must be in Programming mode, see Chap. 7

	Buttons	LED / Audible beep
1	7 2 (enables the function)	Yellow LED
2A1	Enables open door forced detection. Press 1 then #	OK = Green LED + 1 Beep
2A2	Enter the alarm duration from 1 to 300 sec., then press #	OK = Green LED + 1 Beep Error = 3 Beeps
2A3	Buzzer: 1 = Enabled / 2 = Disabled (during the alarm) then press #	OK = Green LED + 1 Beep Error = 3 Beeps
2A4 OR 2B	Alarm output (a): 1 = Enabled / 2 = Disabled (during the alarm) then press #	OK = Green LED + 2 Beeps Error = 3 Beeps
	Disables open door forced detection (default adjustment) Press 2 then #	OK = Green LED + 2 Beeps Error = 3 Beeps
3	Enter another function or press * to exit from Programming mode	Yellow LED OR Blue LED
(a) The alarm output works only when the device is powered in DC		

11.3 - MAX.NUMBER OF WRONG ATTEMPTS ALARM

After 10 wrong attempts of Card/Tag reading or wrong entering of PIN code, the keypad will block and any attempt will not be possible for 10 minutes. The Doorbell button mode will be enabled even if the alarm is working.

The device must be in Programming mode, see Chap. 7

	Buttons	LED / Audible beep
1	[7] [3] (enables the function)	Yellow LED
2A1	Alarm enabled. Press [1] then [#]	OK = Green LED + 1 Beep
2A2	Enter the alarm duration from 1 to 300 sec., then press [#]	OK = Green LED + 1 Beep Error = 3 Beeps
2A3	Buzzer: [1] = Enabled / [2] = Disabled (during the alarm) then press [#]	OK = Green LED + 1 Beep Error = 3 Beeps
2A4 OR	Alarm output (a): [1] = Enabled / [2] = Disabled (during the alarm) then press [#]	OK = Green LED + 2 Beeps Error = 3 Beeps
2B	Alarm disabled (default adjustment) Press [2] then [#]	OK = Green LED + 2 Beeps Error = 3 Beeps
3	Enter another function or press [*] to exit from Programming mode	Yellow LED OR Blue LED
(a) The alarm output works only when the device is powered in DC		

11.4 - ANTI-TAMPERING ALARM

Interruption of the alarm when you close again the reader-keypad and by the reading of a Card/Tag or a valide PIN code.

The device must be in Programming mode, see Chap. 7

	Buttons	LED / Audible Beep
1	[7] [4] (enables the function)	Yellow LED
2A1	Anti-tampering alarm enabled Press [1] then [#]	OK = Green LED + 1 Beep
2A2	Enter the duration of the alarm from 1 to 300 sec, then press [#]	OK = Green LED + 1 Beep Error = 3 Beeps

2A3	Buzzer: [1] = Enabled / [2] = Disabled (during the alarm) then press [#]	OK = Green LED + 1 Beep Error = 3 Beeps
2A4 or 2B	Alarm output (a): [1] = Enabled / [2] = Disabled (during the alarm) then press [#] Alarm disabled (default adjustment) Press [2] then [#]	OK = Green LED + 2 Beeps Error = 3 Beeps OK = Green LED + 2 Beeps Error = 3 Beeps
3	Enter another function or press [*] to exit from Programming mode	Yellow LED OR Blue LED

(a) The alarm output works only when the device is powered in DC

12 - BACK TO FACTORY PARAMETERS



This procedure allows to reset the default factory parameters. It does not cancel the users programmed (for User/s Cancellation, see Chap. 9.4).

- > Turn off the power from the device.
- > Push the button [*] and hold it down.
- > Supply power to the device.
- > At the end of 4 beeps, release button [*]

13 - DIMENSIONS

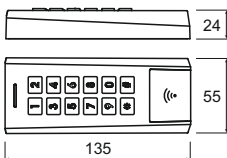

14 - STATUS OUTPUTS

Status	LED / Audible beep
Stand-by (in normal operation / on standby)	Blue LED
Relay 1 and/or Relay 2 enabled	Green LED AND / OR Blue LED + 1 Beep
Wrong PIN code or Card/Tag	Red LED + 5 Beeps
In alarm	Red LED + Beep for the duration of the alarm



The assembly, connections and startup of this product must be necessarily made by personnel qualified in electrical installations.
In case of doubt about the activation or operation of this product, please call your dealer.

DECLARATION OF CONFORMITY CE

The manufacturer:

GI.BI.DI. S.r.l.

Via Abetone Brennero, 177/B,
46025 Poggio Rusco (MN) - ITALY

declares that the product:

MULTIFUNCTION KEYPAD DCD300

Code: AU02201

is in conformity with the following Directives:

- **2014/53/UE**
- **2011/65/UE**

and that the following harmonised Standards have been applied:

- **EN 62368-1: 2014+A11: 2017**
- **EN 62311: 2008**
- **ETSI EN 301 489-1 V2.2.3 (2019-11)**
- **ETSI EN 301 489-3 V2.1.1 (2019-03)**
- **EN 55032: 2015** • **EN 55035: 2017**
- **ETSI EN 300 330 V2.1.1 (2017-02)**

This declaration of conformity is issued under the exclusive responsibility of the manufacturer.

Date 28/09/2021

The legal representative
Michele Prandi

UKCA DECLARATION BY THE MANUFACTURER: The UKCA declaration of conformity is available at: <http://conformity.gibidi.com>



GI.BI.DI.

Cod. AIC6571 - 10/2021 - Rev. 02

GI.BI.DI. S.r.l. - Via Abetone Brennero, 177/B
46025 Poggio Rusco (MN) - ITALY
Tel. +39.0386.52.20.11 - Fax +39.0386.52.20.31
www.gibidi.com - E-mail: info@gibidi.com